



Filter - Regulator - Lubricator



Quick Reference Guide



Body Size	Port Size	Description
FA2	1/8, 1/4	FRL
FA3	1/4, 3/8	Filter, regulator, lubricator
FA4	1/2, 3/4	(Pages 4 & 5)
FA5	3/4, 1	



Body Size	Port Size	Description
FA2	1/8, 1/4	CL
FA3	1/4, 3/8	Filter regulator, lubricator
FA4	1/2, 3/4	(Pages 6 & 7)
FA5	3/4, 1	



Body Size	Port Size	Description
FA2	1/8, 1/4	CM
FA3	1/4, 3/8	Filter regulator, mist separator
FA4	1/2, 3/4	(Pages 8 & 9)



Body Size	Port Size	Description
FA2	1/8, 1/4	FR
FA3	1/4, 3/8	Filter, regulator
FA4	1/2, 3/4	(Pages 10 & 11)
FA5	3/4, 1	



Body Size	Port Size	Description
FA2	1/8, 1/4	FMR -Filter, mist separator, regulator
FA3	1/4, 3/8	(Pages 12 & 13)
FA4	1/2, 3/4	



Body Size	Port Size	Description
FA2	1/8	Gauges
FA3	1/8	(Page 22)
FA4	1/4	
FA5	1/4	



Accessories and Parts		
Pages 22 and 23		



Body Size	Port Size	Description
FA2	1/8, 1/4	C
FA3	1/4, 3/8	Filter, regulator combo
FA4	1/2, 3/4	(Pages 14 & 15)
FA5	3/4, 1	



Body Size	Port Size	Description
FA2	1/8, 1/4	F
FA3	1/4, 3/8	Filter
FA4	1/2, 3/4	(Pages 16 & 17)
FA5	3/4, 1	



Body Size	Port Size	Description
FA2	1/8, 1/4	M
FA3	1/4, 3/8	Mist Separator
FA4	1/2, 3/4	(Pages 16 & 17)



Body Size	Port Size	Description
FA2	1/8, 1/4	R
FA3	1/4, 3/8	Regulator
FA4	1/2, 3/4	(Pages 18 & 19)
FA5	3/4, 1	



Body Size	Port Size	Description
FA2	1/8, 1/4	L
FA3	1/4, 3/8	Lubricator
FA4	1/2, 3/4	(Pages 20 & 21)
FA5	3/4, 1	



Body Size	Port Size	Description
FA2	1/8, 1/4	Lock out, tag out valve
FA3	1/4, 3/8	(Page 22)
FA4	1/2, 3/4	



Body Size	Port Size	Description
FA2	1/4	3-way slide valve
FA3	3/8	(Page 23)
FA4	1/2	

1 Year Warranty

We warrant the Filter-Regulator-Lubricator product to be free from defects in material and workmanship for a period of one (1) year from the date of shipment from Fabco-Air.

(See **Product Precautions** on pages 17, 19 and 21.)

How to Order

- Size** (Regulator Max. SCFM @ 102 psi)
- 2 .. (28 SCFM)
 - 3 .. (53 SCFM)
 - 4 .. (106 SCFM)
 - 5 .. (350 SCFM)

- Description**
- Filter F
 - Mist Separator (1µ filtration)..... M
 - Regulator R
 - Lubricator L
 - Filter/Regulator Combo..... C
 - Combo with Lubricator CL
 - Filter, Regulator..... FR
 - Filter, Regulator, Lubricator..... FRL
 - Combo with Mist Separator CM
 - Filter, Mist Separator, Regulator FMR

Regulators feature these gauges as standard:
Sizes 2, 3 & 4; square embedded (psi scale).
Size 5; round 1/4 NPT (bar and psi scale).

Series



Port Size NPT

- 1/8 (Size 2 only) 1P
- 1/4 (Size 2 and 3) 2P
- 3/8 (Size 3 only) 3P
- 1/2 (Size 4 only) 4P
- 3/4 (Size 4 and 5) 5P
- 1 (Size 5 only)..... 6P

- Drain** (requires 15 psi min.)
- Auto Drain, Float Type..... A
 - Pressure Differential Drain M (also allows manual release of fluids)

Filter Rating – Option

- Leave blank for standard
- (5µ filtration std for sizes 2, 3 & 4; 40µ filtration std for size 5)
- 5µ for size 5 1
- 25µ for sizes 2, 3, 4 & 5 2
- 40µ for sizes 2, 3 & 4 3

Pressure Range for Regulator - Option

- Leave blank for standard 5 to 125 psi range
- 5 to 35 psi.....L
- 5 to 60 psi..... S

Gauge - Option

- Leave blank for standard
- Block off plate..... B
- 1/8 NPT adapter plate C
- 1/4 NPT adapter plate D
- Round gauge w/adapter plate
- Small 1/8 NPT..... F
- Large 1/4 NPT..... G
- Square embedded MPa.... M

Example



Model Number **FA2-FMR2PM**

Series FA, body size 2, filter-mist separator-regulator, 1/4 NPT ports, with manual drains and standard pressure gauge.

Filter - Regulator - Lubricator with two "L" Type Mounting Brackets

FABCO-AIR, Inc. • 3716 N.E. 49th Avenue • Gainesville, FL 32609 • Tel (352) 373-3578



L-Type mounting brackets standard with FRLs.



"T" Ported Interface available - see page 22

Optional 3-way lockout/tagout valve shown. See page 23.

Polycarbonate bowls are standard for all models.

Regulators feature square embedded outlet pressure gauge with psi scale. (145 psi = 1.0 MPa = 10 bar).



Plastic bowl guards are standard for all models

SEE PRODUCT PRECAUTIONS ON PAGES 17, 19 AND 21.

How to Order

Description: Filter, Regulator, Lubricator

Series FA; Size 2, 3, 4 or 5

FA3 - FRL 2P A

Pressure range for regulator - Option:

Blank for standard 5 to 125 psi

L = 5 to 35 psi

S = 5 to 60 psi

Port Size NPT:

1P=1/8; 2P=1/4; 3P=3/8; 4P=1/2; 5P=3/4; 6P=1

Drain (requires 15 psi min.): A = Auto drain, float type

M = Manual/Pressure differential drain[‡]

Filter rating - Option:

(blank for standard of 5µ for sizes 2, 3 & 4; 40µ for size 5)

1 = 5µ; 2 = 25µ; 3 = 40µ

Gauge - Option:

Blank for standard

B = Block off plate

C = 1/8 NPT adapter plate

D = 1/4 NPT adapter plate

F = Small round gauge with 1/8 NPT adapter plate

G = Large round gauge with 1/4 NPT adapter plate

M = Square embedded MPa scale

[‡] Manual drain also opens as inlet pressure is reduced to less than 5 psi.

External Dimensions - inch (mm)

Size FA2

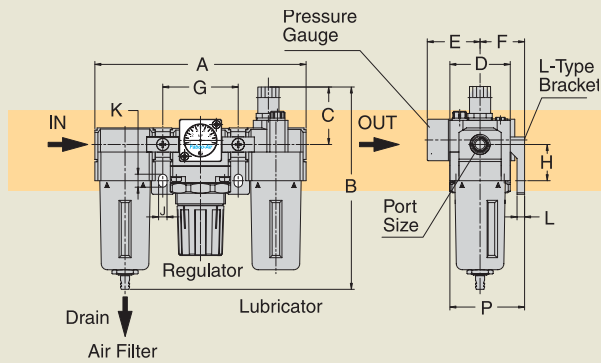

Sizes FA3, 4 & 5

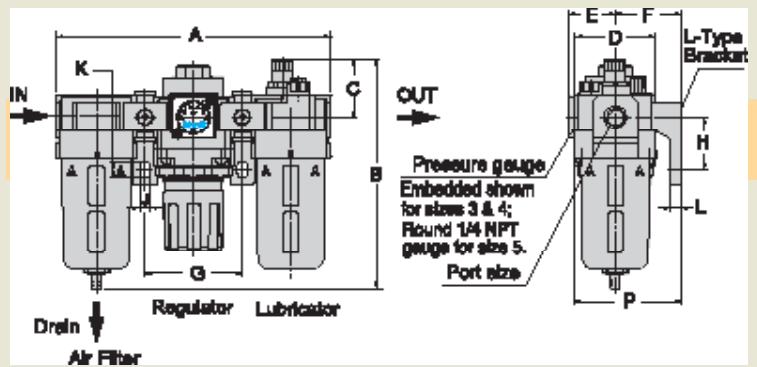

Body Size	Port Size	A	C	D	E	F	G	H	J	K	L	P	B Dimension	
													Manual Drain	Auto Drain Float type
FA2	1/8, 1/4	5.5(140)	1.6(40)	1.6(40)	1.3(34)	1.2(30)	2.0(50)	0.9(24)	0.22(5.5)	0.33(8.5)	0.2(5)	2.0(50)	5.5(140)	5.3(134)
FA3	1/4, 3/8	7.1(181)	1.7(44)	2.1(53)	1.2(30)	1.6(41)	2.5(64)	1.4(35)	0.28(7.0)	0.43(11)	0.3(7)	2.7(67.5)	6.3(160)	6.6(169)
FA4	1/2, 3/4	9.4(238)	1.9(48)	2.8(70)	1.5(38)	2.0(50)	3.3(84)	1.6(40)	0.35(9.0)	0.51(13)	0.3(7)	2.8(70)	8.4(214)	8.4(213)
FA5	3/4, 1	11.1(282)	1.7(43)	3.5(90)	3.3(84)	2.8(70)	3.8(96)	2.0(50)	0.47(12)	0.63(16)	0.4(10)	4.5(115)	12.2(309.5)	11.7(297)

Specifications

Series / Model Size	FA2	FA3	FA4	FA5
Port size NPT	1/8, 1/4	1/4, 3/8	1/2, 3/4	3/4, 1
Operating media	Air			
Max. operating pressure: psi (MPa) (bar)	145 (1.0) (10)			
Regulating range: psi (MPa) (bar)	Standard: 5 to 125 (0.04 to 0.85) (0.4 to 8.5)			
Max. flow rate*	28(800)	53(1500)	106(3000)	350(10000)
Temperature range	-5° to 52°C (+23° to 125°F)			
Filtration Standard	5μ	5μ	5μ	40μ
Recommended oil	Turbine oil (ISO VG32) Exxon Terrestrial GT32, Castrol Hyspin R&O 32, or equal			
Bowl material	Polycarbonate			
Construction / Regulator	Relieving type			
Weight lb.(Kg)	1.5(0.7)	2.2(1)	4.4(2)	8.4(3.8)

* Flow SCFM (Lpm) @ 102psi (0.7 MPa)(7bar) inlet pressure.

Accessories and Mounting See pages 22 & 23.

Accessories	FA2	FA3	FA4	FA5
Round Pressure Gauge	GR-1P†	GR-1P†	GR-2P†	GR-2P
Square Embedded Gauge	GS-P (psi scale) or GS-M (MPa scale)			NA
Standard Interface	NS2	NS3	NS4	NS5
"T" Ported Interface	NT2-1P, NT2-2P	NT3-1P, NT3-2P	NT4-2P, NT4-3P	NA
Lock Out/Tag Out Valve	LT2-1P, LT2-2P	LT3-2P, LT3-3P	LT4-4P, LT4-5P	NA
Sleeve Valve	SV-2P	SV-2P; SV-3P	SV-4P	NA
Mounting				
L-Type Mounting Bracket	MBL2	MBL3	MBL4	MBL5
T-Type Mounting Bracket	MBT2	MBT3	MBT4	MBT5

† Round gauge requires gauge adapter plate #GA-1P (for 1/8 NPT) or #GA-2P (for 1/4 NPT).

Ordering Examples

Port NPT	Model No. Manual drain‡	Model No. Auto drain
1/8	FA2-FRL1PM	FA2-FRL1PA
1/4	FA2-FRL2PM	FA2-FRL2PA
1/4	FA3-FRL2PM	FA3-FRL2PA
3/8	FA3-FRL3PM	FA3-FRL3PA
1/2	FA4-FRL4PM	FA4-FRL4PA
3/4	FA4-FRL5PM	FA4-FRL5PA
3/4	FA5-FRL5PM	FA5-FRL5PA
1	FA5-FRL6PM	FA5-FRL6PA

‡ Manual drain also opens as inlet pressure is reduced to less than 5 psi.

Replacement Parts See page 23.

Filter Element: 5μ, 25μ & 40μ
Complete Bowl w/Auto Drain
Complete Bowl w/Manual Drain
Bowl only for filter
Bowl Guard for filter or lubricator
Regulator Diaphragm
Regulator Knob
Lubricator Bowl
Lubricator Pickup Tube (w/filter when applicable)
Lubricator Adjuster w/sight dome included
Lubricator Plug for Fill Port

Flow Characteristics - Inlet pressure = 102 psi

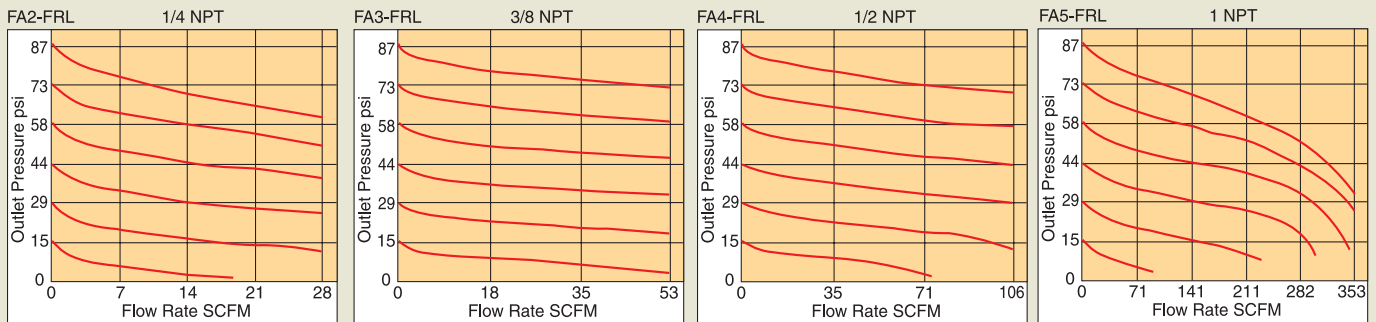

Pressure Characteristics

Set point conditions: Inlet pressure = 102 psi; Outlet pressure = 29 psi; Flow rate = 0.7 SCFM

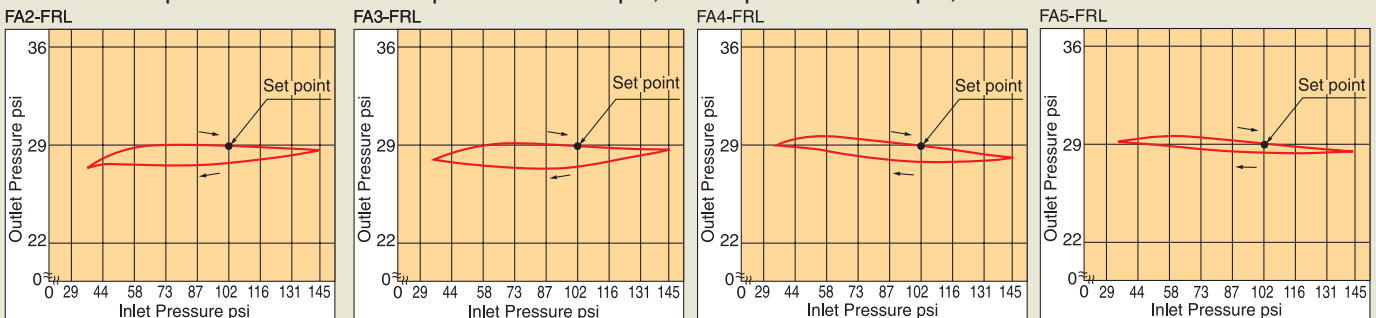

Filter / Regulator Combo with Lubricator and "T" Type Mounting Bracket

FABCO-AIR, Inc. • 3716 N.E. 49th Avenue • Gainesville, FL 32609 • Tel (352) 373-3578



Filter/Regulator Combo with Lubricator features square embedded outlet pressure gauge with psi scale (145 psi = 1.0 MPa = 10 bar) and one "T" Type mounting bracket.



"T" Type mounting bracket.

SEE PRODUCT PRECAUTIONS ON PAGES 17, 19 AND 21.

How to Order

Description: Filter/Regulator Combo, Lubricator

Series FA; Size 2, 3, 4 or 5

FA3 - **CL** - **2P** - **A** - [] - [] - []

Port Size NPT:

1P=1/8; 2P=1/4; 3P=3/8; 4P=1/2; 5P=3/4; 6P=1

Drain (requires 15 psi min.): A = Auto drain, float type

M = Manual/Pressure differential drain[‡]

Filter rating - Option:

(blank for standard of 5µ for sizes 2, 3 & 4; 40µ for size 5)

1 = 5µ; 2 = 25µ; 3 = 40µ

Pressure range for regulator - Option:

Blank for standard 5 to 125 psi

L = 5 to 35 psi

S = 5 to 60 psi

Gauge - Option:

Blank for standard

B = Block off plate

C = 1/8 NPT adapter plate

D = 1/4 NPT adapter plate

F = Small round gauge with 1/8 NPT adapter plate

G = Large round gauge with 1/4 NPT adapter plate

M = Square embedded MPa scale

[‡] Manual drain also opens as inlet pressure is reduced to less than 5 psi.

External Dimensions - inch (mm)

Size FA2

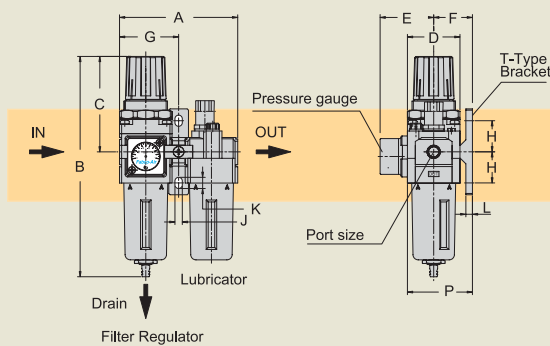

Sizes FA3, 4 & 5

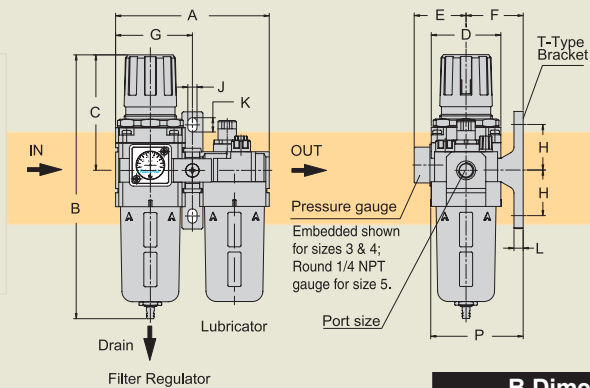

B Dimension

Body Size	Port Size	A	C	D	E	F	G	H	J	K	L	P	B Dimension	
													Manual Drain	Auto Drain Float type
FA2	1/8, 1/4	3.5(90)	3.0(76)	1.6(40)	1.3(34)	1.2(30)	1.8(45)	0.9(24)	0.22(5.5)	0.33(8.5)	0.2(5)	2.0(50)	6.5(166)	6.8(172)
FA3	1/4, 3/8	4.6(117)	3.5(88)	2.1(53)	1.2(30)	1.6(41)	2.3(58.5)	1.4(35)	0.28(7.0)	0.43(11)	0.3(7)	2.7(67.5)	8.1(205)	8.0(203)
FA4	1/2, 3/4	6.1(154)	3.4(87)	2.8(70)	1.5(38)	2.0(50)	3.0(77)	1.6(40)	0.35(9.0)	0.51(13)	0.3(7)	2.8(70)	10.1(257)	10.0(255)
FA5	3/4, 1	7.7(195)	4.8(122)	3.5(90)	3.1(80)	2.8(70)	3.8(97)	2.0(50)	0.47(12)	0.63(16)	0.4(10)	4.4(112)	13.0(330)	13.4(340)

Specifications

Series / Model Size	FA2	FA3	FA4	FA5
Port size NPT	1/8, 1/4	1/4, 3/8	1/2, 3/4	3/4, 1
Operating media	Air			
Max. operating pressure: psi (MPa) (bar)	145 (1.0) (10)			
Regulating range: psi (MPa) (bar)	Standard: 5 to 125 (0.04 to 0.85) (0.4 to 8.5)			
Max. flow rate*	28(800)	53(1500)	106(3000)	350(10000)
Temperature range	-5° to 52°C (+23° to 125°F)			
Filtration Standard	5μ	5μ	5μ	40μ
Recommended oil	Turbine oil (ISO VG32) Exxon Terrestrial GT32, Castrol Hyspin R&O 32, or equal			
Bowl material	Polycarbonate			
Construction / Regulator	Relieving type			
Weight lb.(Kg)	1.5(0.7)	2.2(1)	4.4(2)	8.4(3.8)

* Flow SCFM (Lpm) @ 102psi (0.7 MPa)(7bar) inlet pressure.

Accessories and Mounting See pages 22 & 23.

Accessories	FA2	FA3	FA4	FA5
Round Pressure Gauge	GR-1P†	GR-1P†	GR-2P†	GR-2P
Square Embedded Gauge	GS-P (psi scale) or GS-M (MPa scale)			
Standard Interface	NS2	NS3	NS4	NS5
"T" Ported Interface	NT2-1P, NT2-2P	NT3-1P, NT3-2P	NT4-2P, NT4-3P	NA
Lock Out/Tag Out Valve	LT2-1P, LT2-2P	LT3-2P, LT3-3P	LT4-4P, LT4-5P	NA
Sleeve Valve	SV-2P	SV-2P; SV-3P	SV-4P	NA
Mounting				
L-Type Mounting Bracket	MBL2	MBL3	MBL4	MBL5
T-Type Mounting Bracket	MBT2	MBT3	MBT4	MBT5

† Round gauge requires gauge adapter plate #GA-1P (for 1/8 NPT) or #GA-2P (for 1/4 NPT).

Ordering Examples

Port NPT	Model No. Manual drain†	Model No. Auto drain
1/8	FA2-CL1PM	FA2-CL1PA
1/4	FA2-CL2PM	FA2-CL2PA
1/4	FA3-CL2PM	FA3-CL2PA
3/8	FA3-CL3PM	FA3-CL3PA
1/2	FA4-CL4PM	FA4-CL4PA
3/4	FA4-CL5PM	FA4-CL5PA
3/4	FA5-CL5PM	FA5-CL5PA
1	FA5-CL6PM	FA5-CL6PA

† Manual drain also opens as inlet pressure is reduced to less than 5 psi.

Replacement Parts See page 23.

Filter Element: 5μ, 25μ & 40μ
Complete Bowl w/Auto Drain
Complete Bowl w/Manual Drain
Bowl only for filter
Bowl Guard for Filter or Lubricator
Regulator Diaphragm
Regulator Knob
Lubricator Bowl
Lubricator Pickup Tube (w/filter when applicable)
Lubricator Adjuster w/sight dome included
Lubricator Plug for Fill Port

Flow Characteristics - Inlet pressure = 102 psi

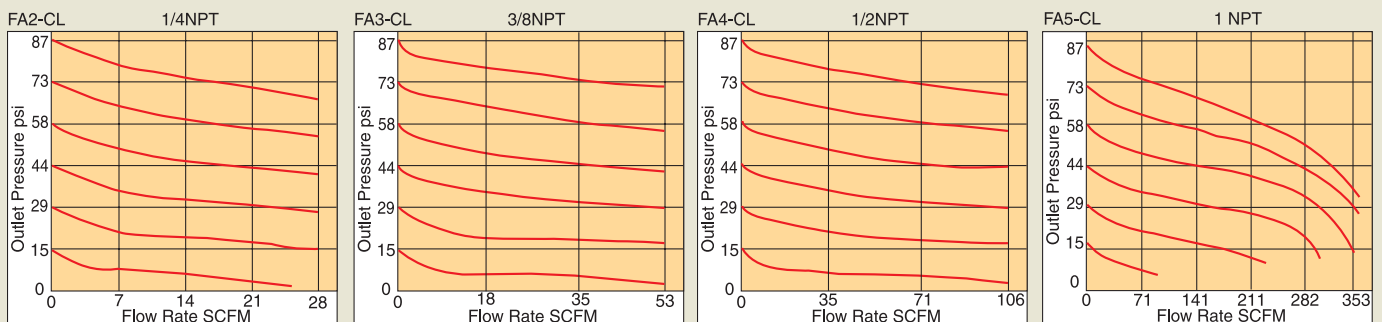

Pressure Characteristics

Set point conditions: Inlet pressure = 102 psi; Outlet pressure = 29 psi; Flow rate = 0.7 SCFM

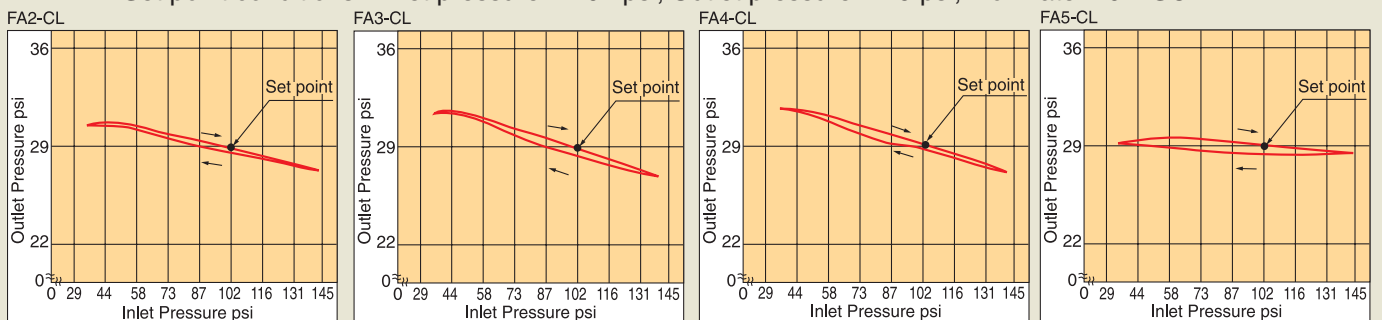

Filter/Regulator Combo with Mist Separator and "T" Type Mounting Bracket

FABCO-AIR, Inc. • 3716 N.E. 49th Avenue • Gainesville, FL 32609 • Tel (352) 373-3578



Filter/Regulator Combo with Mist Separator features square embedded outlet pressure gauge with psi scale (145 psi = 1.0 MPa = 10 bar) and one "T" Type mounting bracket.



SEE PRODUCT PRECAUTIONS ON PAGES 17, 19 AND 21.

How to Order

Description:

Filter/Regulator Combo, Mist Separator

Series FA; Size 2, 3 or 4

FA3 - CM 2P M

Port Size NPT:

1P=1/8; 2P=1/4; 3P=3/8; 4P=1/2; 5P=3/4

Drain (requires 15 psi min.): A = Auto drain, float type

M = Manual/Pressure differential drain[‡]

Pressure range for regulator - Option:

Blank for standard 5 to 125 psi

L = 5 to 35 psi

S = 5 to 60 psi

[‡] Manual drain also opens as inlet pressure is reduced to less than 5 psi.

Gauge - Option:

Blank for standard

B = Block off plate

C = 1/8 NPT adapter plate

D = 1/4 NPT adapter plate

F = Small round gauge with 1/8 NPT adapter plate

G = Large round gauge with 1/4 NPT adapter plate

M = Square embedded MPa scale

External Dimensions - inch (mm)

Size FA2

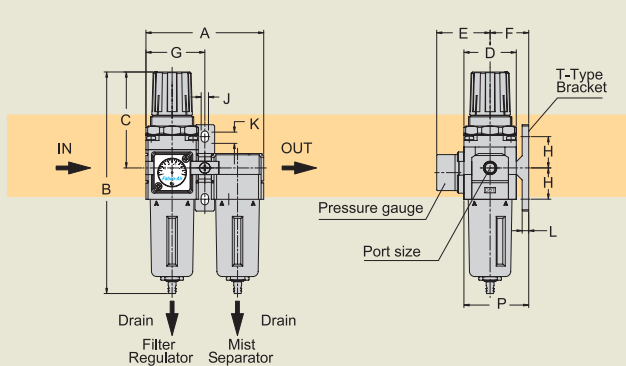

Sizes FA3 & 4

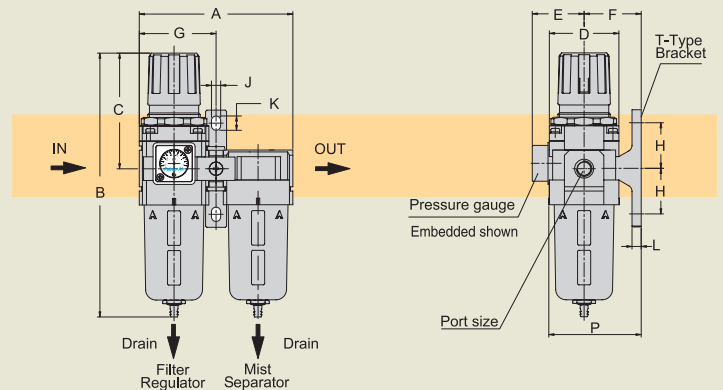

Body Size	Port Size	A	C	D	E	F	G	H	J	K	L	P	B Dimension	
													Manual Drain	Auto Drain Float type
FA2	1/8, 1/4	3.5(90)	3.0(76)	1.6(40)	1.3(34)	1.2(30)	1.8(45)	0.9(24)	0.22(5.5)	0.33(8.5)	0.2(5)	2.0(50)	6.5(166)	6.8(172)
FA3	1/4, 3/8	4.6(117)	3.5(88)	2.1(53)	1.2(30)	1.6(41)	2.3(58.5)	1.4(35)	0.28(7.0)	0.43(11)	0.3(7)	2.7(67.5)	8.1(205)	8.0(203)
FA4	1/2, 3/4	6.1(154)	3.4(87)	2.8(70)	1.5(38)	2.0(50)	3.0(77)	1.6(40)	0.35(9.0)	0.51(13)	0.3(7)	2.8(70)	10.1(257)	10.0(255)

Specifications

Series / Model Size		FA2	FA3	FA4
Port size	NPT	1/8, 1/4	1/4, 3/8	1/2, 3/4
Operating media		Air		
Max. operating pressure: psi (MPa) (bar)		145 (1.0) (10)		
Regulating range: psi (MPa) (bar)		Standard: 5 to 125 (0.04 to 0.85) (0.4 to 8.5)		
Max. flow rate*		5.3(150)	11.6(330)	28(800)
Temperature range		-5° to 52°C (+23° to 125°F)		
Filtration		Standard: 1µm		
Bowl material		Polycarbonate		
Construction / Regulator		Relieving type		
Weight	lb.(Kg)	1.0(0.45)	1.7(0.75)	3.3(1.5)

* Flow SCFM (Lpm) @ 102psi (0.7 MPa)(7bar) inlet pressure.

Accessories and Mounting

See pages 22 & 23.

Accessories	FA2	FA3	FA4
Round Pressure Gauge	GR-1P†	GR-1P†	GR-2P†
Square Embedded Gauge	GS-P (psi scale) or GS-M (MPa scale)		
Standard Interface	NS2	NS3	NS4
"T" Ported Interface	NT2-1P, NT2-2P	NT3-1P, NT3-2P	NT4-2P, NT4-3P
Lock Out/Tag Out Valve	LT2-1P, LT2-2P	LT3-2P, LT3-3P	LT4-4P, LT4-5P
Sleeve Valve	SV-2P	SV-2P; SV-3P	SV-4P
Mounting			
L-Type Mounting Bracket	MBL2	MBL3	MBL4
T-Type Mounting Bracket	MBT2	MBT3	MBT4

† Round gauge requires gauge adapter plate #GA-1P (for 1/8 NPT) or #GA-2P (for 1/4 NPT).

Ordering Examples

Port NPT	Model No. Manual drain‡	Model No. Auto drain
1/8	FA2-CM1PM	FA2-CM1PA
1/4	FA2-CM2PM	FA2-CM2PA
1/4	FA3-CM2PM	FA3-CM2PA
3/8	FA3-CM3PM	FA3-CM3PA
1/2	FA4-CM4PM	FA4-CM4PA
3/4	FA4-CM5PM	FA4-CM5PA

‡ Manual drain also opens as inlet pressure is reduced to less than 5 psi.

Replacement Parts

See page 23.

Filter Element: 1µ, 5µ, 25µ & 40µ
Complete Bowl w/Auto Drain
Complete Bowl w/Manual Drain
Bowl only for Filter / Mist Separator
Bowl Guard for Filter / Mist Separator
Regulator Diaphragm
Regulator Knob

Filter with Regulator features square embedded outlet pressure gauge with psi scale (145 psi = 1.0 MPa = 10 bar) and one "T" Type mounting bracket.



SEE PRODUCT PRECAUTIONS ON PAGES 17, 19 AND 21.

How to Order

Description: Filter with Regulator

Series FA; Size 2, 3, 4 or 5

FA4 - FR 5P M

Pressure range for regulator - Option:

Blank for standard 5 to 125 psi

L = 5 to 35 psi

S = 5 to 60 psi

Port Size NPT:

1P=1/8; 2P=1/4; 3P=3/8; 4P=1/2; 5P=3/4; 6P=1

Drain (requires 15 psi min.): A = Auto drain, float type

M = Manual/Pressure differential drain[‡]

Filter rating - Option:

(blank for standard of 5µ for sizes 2, 3 & 4; 40µ for size 5)

1 = 5µ; 2 = 25µ; 3 = 40µ

Gauge - Option:

Blank for standard

B = Block off plate

C = 1/8 NPT adapter plate

D = 1/4 NPT adapter plate

F = Small round gauge with 1/8 NPT adapter plate

G = Large round gauge with 1/4 NPT adapter plate

M = Square embedded MPa scale

[‡] Manual drain also opens as inlet pressure is reduced to less than 5 psi.

External Dimensions - inch (mm)

Size FA2

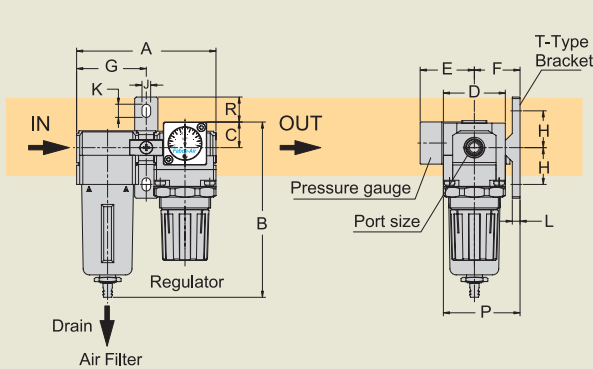

Sizes FA3, 4 & 5

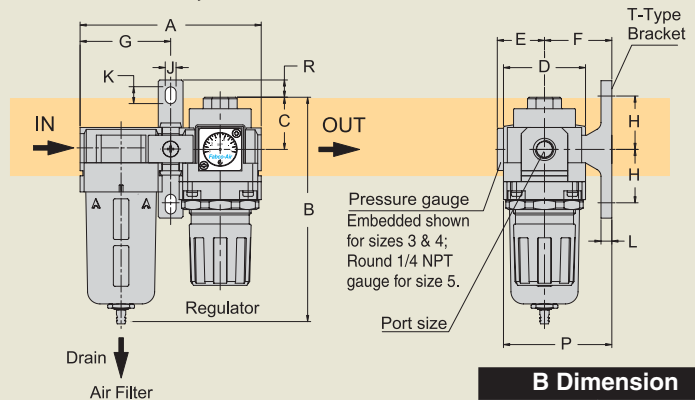

B Dimension

Body Size	Port Size	A	C	D	E	F	G	H	J	K	L	P	R	B Dimension	
														Manual Drain	Auto Drain Float type
FA2	1/8, 1/4	3.5(90)	0.7(17)	1.6(40)	1.3(34)	1.2(30)	1.8(45)	0.9(24)	0.22(5.5)	0.33(8.5)	0.2(5)	2.0(50)	0.6(16)	4.4(110)	4.3(108)
FA3	1/4, 3/8	4.6(117)	1.3(34)	2.1(53)	1.2(30)	1.6(41)	2.3(58.5)	1.4(35)	0.28(7.0)	0.43(11)	0.3(7)	2.7(67.5)	0.4(11)	5.8(148)	4.5(115)
FA4	1/2, 3/4	6.1(154)	1.6(40)	2.8(70)	1.5(38)	2.0(50)	3.0(77)	1.6(40)	0.35(9.0)	0.51(13)	0.3(7)	2.8(70)	0.5(14)	8.0(202)	8.4(213)
FA5	3/4, 1	7.3(186)	1.7(43)	3.5(90)	3.3(84)	2.8(70)	3.7(93)	2.0(50)	0.47(12)	0.63(16)	0.4(10)	4.5(115)	0.6(16)	10.6(270)	10.6(270)

Specifications

Series / Model Size	FA2	FA3	FA4	FA5
Port size NPT	1/8, 1/4	1/4, 3/8	1/2, 3/4	3/4, 1
Operating media	Air			
Max. operating pressure: psi (MPa) (bar)	145 (1.0) (10)			
Regulating range: psi (MPa) (bar)	Standard: 5 to 125 (0.04 to 0.85) (0.4 to 8.5)			
Max. flow rate*	28(800)	53(1500)	106(3000)	350(10000)
Temperature range	-5° to 52°C (+23° to 125°F)			
Filtration Standard	5μ	5μ	5μ	40μ
Bowl material	Polycarbonate			
Construction / Regulator	Relieving type			
Weight lb.(Kg)	0.6(0.26)	1.0(0.44)	2.2(1.0)	3.7(1.7)

* Flow SCFM (Lpm) @ 102psi (0.7 MPa)(7bar) inlet pressure.

Ordering Examples

Port NPT	Model No. Manual drain [‡]	Model No. Auto drain
1/8	FA2-FR1PM	FA2-FR1PA
1/4	FA2-FR2PM	FA2-FR2PA
1/4	FA3-FR2PM	FA3-FR2PA
3/8	FA3-FR3PM	FA3-FR3PA
1/2	FA4-FR4PM	FA4-FR4PA
3/4	FA4-FR5PM	FA4-FR5PA
3/4	FA5-FR5PM	FA5-FR5PA
1	FA5-FR6PM	FA5-FR6PA

[‡] Manual drain also opens as inlet pressure is reduced to less than 5 psi.

Accessories and Mounting See pages 22 & 23.

Accessories	FA2	FA3	FA4	FA5
Round Pressure Gauge	GR-1P [†]	GR-1P [†]	GR-2P [†]	GR-2P
Square Embedded Gauge	GS-P (psi scale) or GS-M (MPa scale)			NA
Standard Interface	NS2	NS3	NS4	NS5
"T" Ported Interface	NT2-1P, NT2-2P	NT3-1P, NT3-2P	NT4-2P, NT4-3P	NA
Lock Out/Tag Out Valve	LT2-1P, LT2-2P	LT3-2P, LT3-3P	LT4-4P, LT4-5P	NA
Sleeve Valve	SV-2P	SV-2P; SV-3P	SV-4P	NA
Mounting				
L-Type Mounting Bracket	MBL2	MBL3	MBL4	MBL5
T-Type Mounting Bracket	MBT2	MBT3	MBT4	MBT5

[†] Round gauge requires gauge adapter plate #GA-1P (for 1/8 NPT) or #GA-2P (for 1/4 NPT).

Replacement Parts See page 23.

Filter Element: 5μ, 25μ & 40μ
Complete Bowl w/Auto Drain
Complete Bowl w/Manual Drain
Bowl Only for Filter
Bowl Guard for Filter
Regulator Diaphragm
Regulator Knob

Flow Characteristics - Inlet pressure = 102 psi

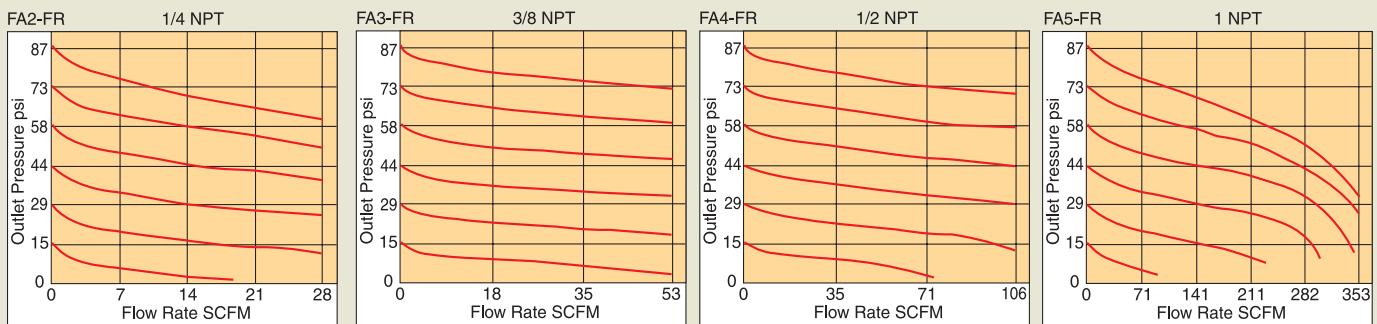

Pressure Characteristics

Set point conditions: Inlet pressure = 102 psi; Outlet pressure = 29 psi; Flow rate = 0.7 SCFM

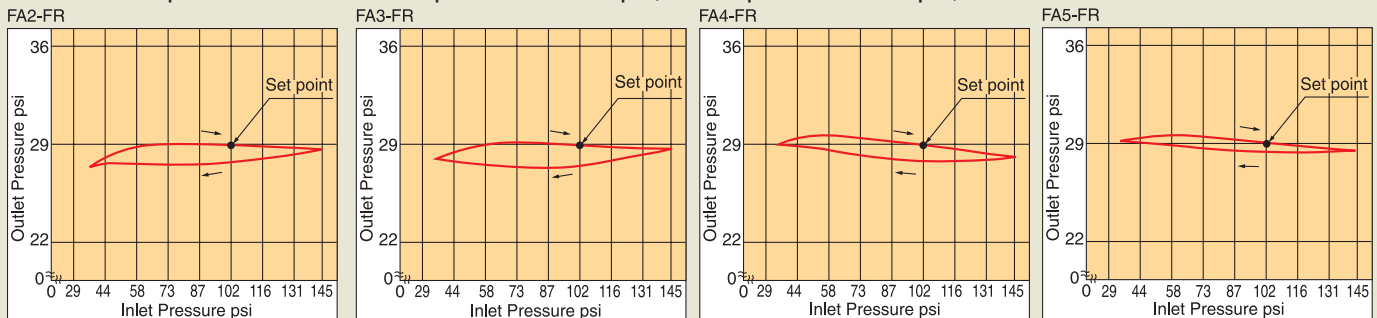

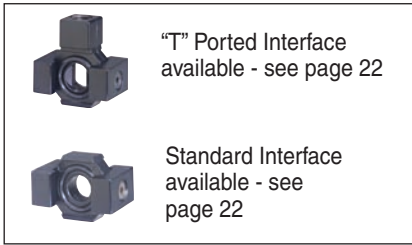

Filter, Mist Separator, Regulator features square embedded outlet pressure gauge with psi scale (145 psi = 1.0 MPa = 10 bar) and two "L" Type mounting brackets.



SEE PRODUCT PRECAUTIONS ON PAGES 17, 19 AND 21.

How to Order

Description: Filter, Mist Separator, Regulator

Series FA; Size 2, 3 or 4

FA4 - FMR 4P A

Port Size NPT:

1P=1/8; 2P=1/4; 3P=3/8; 4P=1/2; 5P=3/4

Drain (requires 15 psi min.): A = Auto drain, float type

M = Manual/Pressure differential drain[‡]

Pressure range for regulator - Option:

Blank for standard 5 to 125 psi

L = 5 to 35 psi

S = 5 to 60 psi

[‡] Manual drain also opens as inlet pressure is reduced to less than 5 psi.

Gauge - Option:

Blank for standard

B = Block off plate

C = 1/8 NPT adapter plate

D = 1/4 NPT adapter plate

F = Small round gauge with 1/8 NPT adapter plate

G = Large round gauge with 1/4 NPT adapter plate

M = Square embedded MPa scale

External Dimensions - inch (mm)

Size FA2

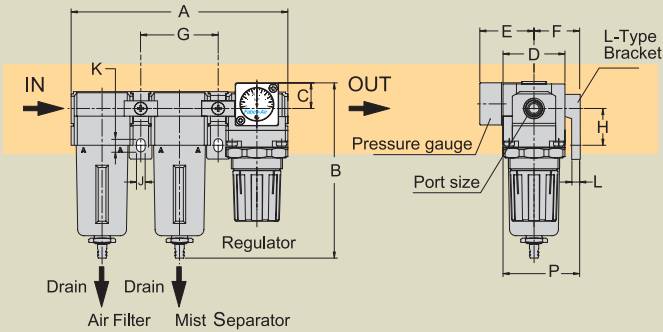

Sizes FA3 & 4

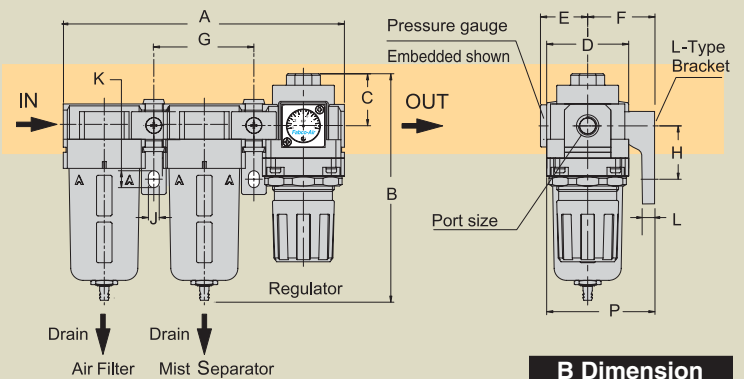

B Dimension

Manual Drain	Auto Drain Float type
--------------	-----------------------

Body Size	Port Size	A	C	D	E	F	G	H	J	K	L	P
FA2	1/8, 1/4	5.5(140)	0.7(17)	1.6(40)	1.3(34)	1.2(30)	2.0(50)	0.9(24)	0.22(5.5)	0.33(8.5)	0.2(5)	2.0(50)
FA3	1/4, 3/8	7.1(181)	1.3(34)	2.1(53)	1.2(30)	1.6(41)	2.5(64)	1.4(35)	0.28(7.0)	0.43(11)	0.3(7)	2.7(67.5)
FA4	1/2, 3/4	9.4(238)	1.6(40)	2.8(70)	1.5(38)	2.0(50)	3.3(84)	1.6(40)	0.35(9.0)	0.51(13)	0.3(7)	2.8(70)

4.3(110)	4.2(108)
5.8(148)	6.1(155)
8.0(202)	8.4(213)

Specifications

Series / Model Size		FA2	FA3	FA4
Port size	NPT	1/8, 1/4	1/4, 3/8	1/2, 3/4
Operating media	Air			
Max. operating pressure: psi (MPa) (bar)	145 (1.0) (10)			
Regulating range: psi (MPa) (bar)	Standard: 5 to 125 (0.04 to 0.85) (0.4 to 8.5)			
Max. flow rate*		7(200)	15.8(450)	38.8(1100)
Temperature range	-5° to 52°C (+23° to 125°F)			
Filtration	Standard: 1µ			
Bowl material	Polycarbonate			
Construction / Regulator	Relieving type			
Weight	lb.(Kg)	0.66(0.3)	1.1(0.5)	2.2(1.0)

* Flow SCFM (Lpm) @ 102psi (0.7 MPa)(7bar) inlet pressure.

Accessories and Mounting

See pages 22 & 23.

Accessories	FA2	FA3	FA4
Round Pressure Gauge	GR-1P†	GR-1P†	GR-2P†
Square Embedded Gauge	GS-P (psi scale) or GS-M (MPa scale)		
Standard Interface	NS2	NS3	NS4
"T" Ported Interface	NT2-1P, NT2-2P	NT3-1P, NT3-2P	NT4-2P, NT4-3P
Lock Out/Tag Out Valve	LT2-1P, LT2-2P	LT3-2P, LT3-3P	LT4-4P, LT4-5P
Sleeve Valve	SV-2P	SV-2P; SV-3P	SV-4P
Mounting			
L-Type Mounting Bracket	MBL2	MBL3	MBL4
T-Type Mounting Bracket	MBT2	MBT3	MBT4

† Note: Round gauge requires gauge adapter plate #GA-1P (for 1/8 NPT) or #GA-2P (for 1/4 NPT).

Ordering Examples

Port NPT	Model No. Manual drain‡	Model No. Auto drain
1/8	FA2-FMR1PM	FA2-FMR1PA
1/4	FA2-FMR2PM	FA2-FMR2PA
1/4	FA3-FMR2PM	FA3-FMR2PA
3/8	FA3-FMR3PM	FA3-FMR3PA
1/2	FA4-FMR4PM	FA4-FMR4PA
3/4	FA4-FMR5PM	FA4-FMR5PA

‡ Manual drain also opens as inlet pressure is reduced to less than 5 psi.

Replacement Parts

See page 23.

Filter Element: 1µ, 5µ, 25µ & 40µ
Complete Bowl w/Auto Drain
Complete Bowl w/Manual Drain
Bowl only for Filter / Mist Separator
Bowl Guard for Filter / Mist Separator
Regulator Diaphragm
Regulator Knob

Filter / Regulator Combo with "MBCR" Type Mounting Bracket

FABCO-AIR, Inc. • 3716 N.E. 49th Avenue • Gainesville, FL 32609 • Tel (352) 373-3578



Steel mounting bracket and panel nut included

Filter/regulator combo units feature square embedded outlet pressure gauge with psi scale (145 psi = 1.0 MPa = 10 bar) and one "MBCR" Type mounting bracket.

SEE PRODUCT PRECAUTIONS ON PAGES 17, 19 AND 21.

How to Order

Description: Filter/Regulator Combo

Series FA; Size 2, 3, 4 or 5

FA3 - C 2P A

Pressure range for regulator - Option:

Blank for standard 5 to 125 psi

L = 5 to 35 psi

S = 5 to 60 psi

Port Size NPT:

1P=1/8; 2P=1/4; 3P=3/8; 4P=1/2; 5P=3/4; 6P=1

Drain (requires 15 psi min.): A = Auto drain, float type

M = Manual/Pressure differential drain†

Filter rating - Option:

(blank for standard of 5µ for sizes 2, 3 & 4; 40µ for size 5)

1 = 5µ; 2 = 25µ; 3 = 40µ

Gauge - Option:

Blank for standard

B = Block off plate

C = 1/8 NPT adapter plate

D = 1/4 NPT adapter plate

F = Small round gauge with 1/8 NPT adapter plate

G = Large round gauge with 1/4 NPT adapter plate

M = Square embedded MPa scale

† Manual drain also opens as inlet pressure is reduced to less than 5 psi.

External Dimensions - inch (mm)

Size FA2

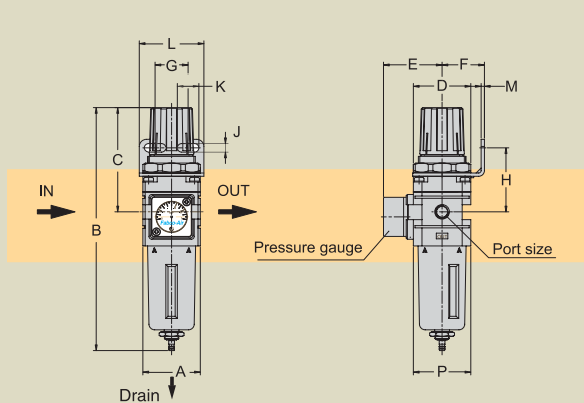

Sizes FA3, 4 & 5

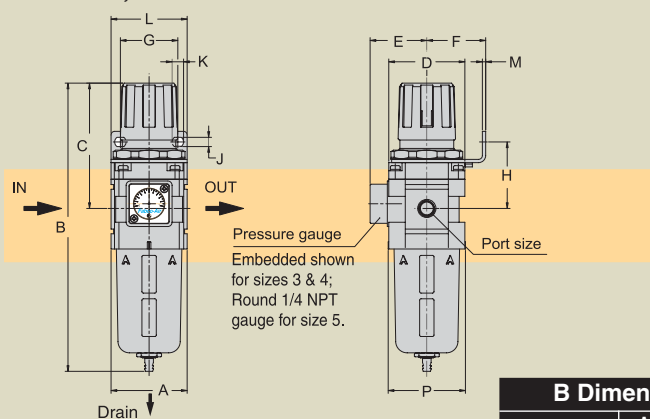

Body Size	Port Size	A	C	D	E	F	G	H	J	K	L	M	P	B Dimension	
														Manual Drain	Auto Drain Float type
FA2	1/8, 1/4	1.6(40)	3.0(76)	1.6(40)	1.3(34)	1.2(30)	1.02(26)	1.8(45)	.21(5.4)	.53(13.4)	1.8(45)	.09(2.3)	1.6(40)	6.5(166)	6.8(172)
FA3	1/4, 3/8	2.1(53)	3.5(88)	2.1(53)	1.2(30)	1.6(41)	1.34(34)	1.8(46)	.26(6.5)	.49(12.5)	2.2(55)	.09(2.3)	2.1(53)	8.1(205)	8.0(203)
FA4	1/2, 3/4	2.8(70)	3.4(87)	2.8(70)	1.5(38)	2.0(50)	1.65(42)	2.1(54)	.33(8.5)	.81(20.5)	2.8(70)	.09(2.3)	2.8(70)	10.1(257)	10.0(255)
FA5	3/4, 1	3.5(90)	4.7(120)	3.5(90)	3.0(75)	2.0(51)	1.75(44.5)	2.5(63)	.26(6.5)	.61(15.5)	2.6(67)	.09(2.3)	3.5(90)	13.0(330)	13.4(340)

Specifications

Series / Model Size	FA2	FA3	FA4	FA5
Port size NPT	1/8, 1/4	1/4, 3/8	1/2, 3/4	3/4, 1
Operating media	Air			
Max. operating pressure: psi (MPa) (bar)	145 (1.0) (10)			
Regulating range: psi (MPa) (bar)	Standard: 5 to 125 (0.04 to 0.85) (0.4 to 8.5)			
Max. flow rate*	28(800)	53(1500)	106(3000)	350(10000)
Temperature range	-5° to 52°C (+23° to 125°F)			
Filtration Standard	5μ	5μ	5μ	40μ
Bowl material	Polycarbonate			
Construction / Regulator	Relieving type			
Weight lb.(Kg)	0.6(0.26)	1.0(0.44)	2.2(1.0)	3.7(1.7)

* Flow SCFM (Lpm) @ 102psi (0.7 MPa)(7bar) inlet pressure.

Ordering Examples

Port NPT	Model No. Manual drain [‡]	Model No. Auto drain
1/8	FA2-C1PM	FA2-C1PA
1/4	FA2-C2PM	FA2-C2PA
1/4	FA3-C2PM	FA3-C2PA
3/8	FA3-C3PM	FA3-C3PA
1/2	FA4-C4PM	FA4-C4PA
3/4	FA4-C5PM	FA4-C5PA
3/4	FA5-C5PM	FA5-C5PA
1	FA5-C6PM	FA5-C6PA

[‡] Manual drain also opens as inlet pressure is reduced to less than 5 psi.

Accessories and Mounting See pages 22 & 23.

Accessories	FA2	FA3	FA4	FA5
Round Pressure Gauge	GR-1P [†]	GR-1P [†]	GR-2P [†]	GR-2P
Square Embedded Gauge	GS-P (psi scale) or GS-M (MPa scale)			NA
Standard Interface	NS2	NS3	NS4	NS5
"T" Ported Interface	NT2-1P, NT2-2P	NT3-1P, NT3-2P	NT4-2P, NT4-3P	NA
Lock Out/Tag Out Valve	LT2-1P, LT2-2P	LT3-2P, LT3-3P	LT4-4P, LT4-5P	NA
Sleeve Valve	SV-2P	SV-2P; SV-3P	SV-4P	NA
Mounting				
MBCR Mounting Bracket	MBCR2	MBCR3	MBCR4	MBCR5

[†] Note: Round gauge requires gauge adapter plate #GA-1P (for 1/8 NPT) or #GA-2P (for 1/4 NPT).

Replacement Parts See page 23.

Filter Element: 5μ, 25μ & 40μ
Complete Bowl w/Auto Drain
Complete Bowl w/Manual Drain
Bowl Only for Filter
Bowl Guard for Filter
Regulator Diaphragm
Regulator Knob

Flow Characteristics - Inlet pressure = 102 psi

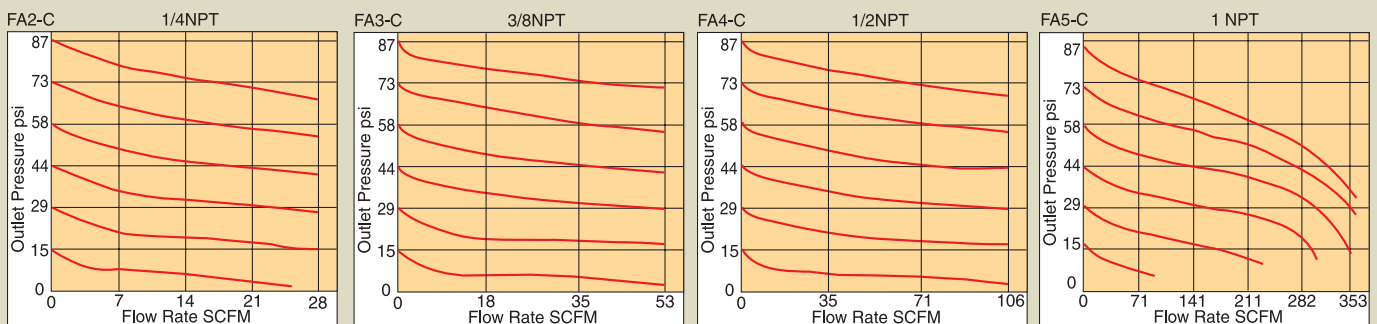

Pressure Characteristics

Set point conditions: Inlet pressure = 102 psi; Outlet pressure = 29 psi; Flow rate = 0.7 SCFM

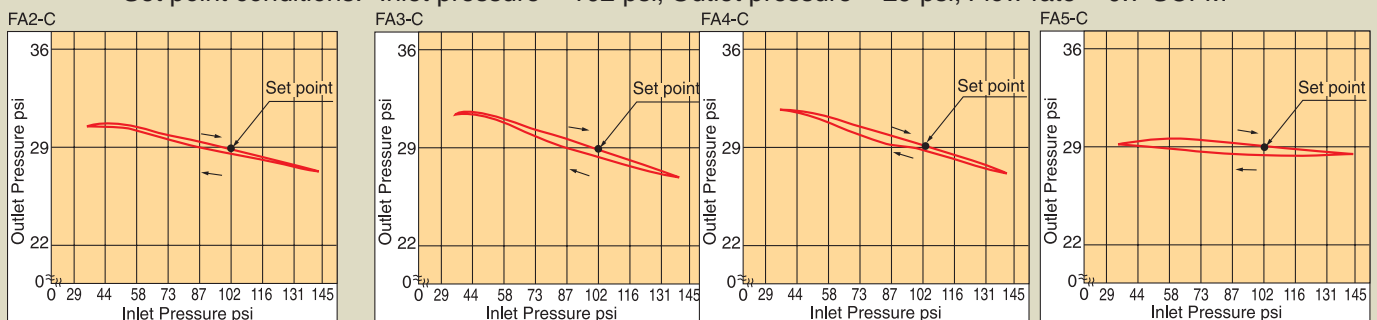



Order Mounting Brackets and Interface Blocks separately. See pages 22 and 23.



**5μ Filter (40μ for size 5)
1μ Mist Separator**

Plastic bowl guards are standard for all models.

Polycarbonate bowls are standard for all models.



SEE PRODUCT PRECAUTIONS ON PAGE 17.

How to Order

Series FA; Size 2, 3, 4 or 5

FA4 - F 4P A

Port Size NPT:

1P=1/8; 2P=1/4; 3P=3/8; 4P=1/2; 5P=3/4; 6P=1

Drain (requires 15 psi min): A = Auto drain, float type

M = Manual/Pressure differential drain (Manual drain also opens as inlet pressure is reduced to less than 5 psi.)

Description:

F = Filter (5μ standard for sizes 2, 3 & 4; 40μ for size 5)

M = Mist Separator (1μ standard for sizes 2, 3 & 4 only)

Filter rating

Filter - Option: (leave blank for standard);

1 = 5μ; 2 = 25μ; 3 = 40μ

Mist Separator (leave blank)

Filter Ordering Examples

Port NPT	Model No. Manual drain [‡]	Model No. Auto drain
1/8	FA2-F1PM	FA2-F1PA
1/4	FA2-F2PM	FA2-F2PA
1/4	FA3-F2PM	FA3-F2PA
3/8	FA3-F3PM	FA3-F3PA
1/2	FA4-F4PM	FA4-F4PA
3/4	FA4-F5PM	FA4-F5PA
3/4	FA5-F5PM	FA5-F5PA
1	FA5-F6PM	FA5-F6PA

Mist Separator Ordering Examples

Port NPT	Model No. Manual drain [‡]	Model No. Auto drain
1/8	FA2-M1PM	FA2-M1PA
1/4	FA2-M2PM	FA2-M2PA
1/4	FA3-M2PM	FA3-M2PA
3/8	FA3-M3PM	FA3-M3PA
1/2	FA4-M4PM	FA4-M4PA
3/4	FA4-M5PM	FA4-M5PA

[‡] Manual drain also opens as inlet pressure is reduced to less than 5 psi.

External Dimensions – inch (mm)

Size FA2

Sizes FA3 & 4

Size FA5

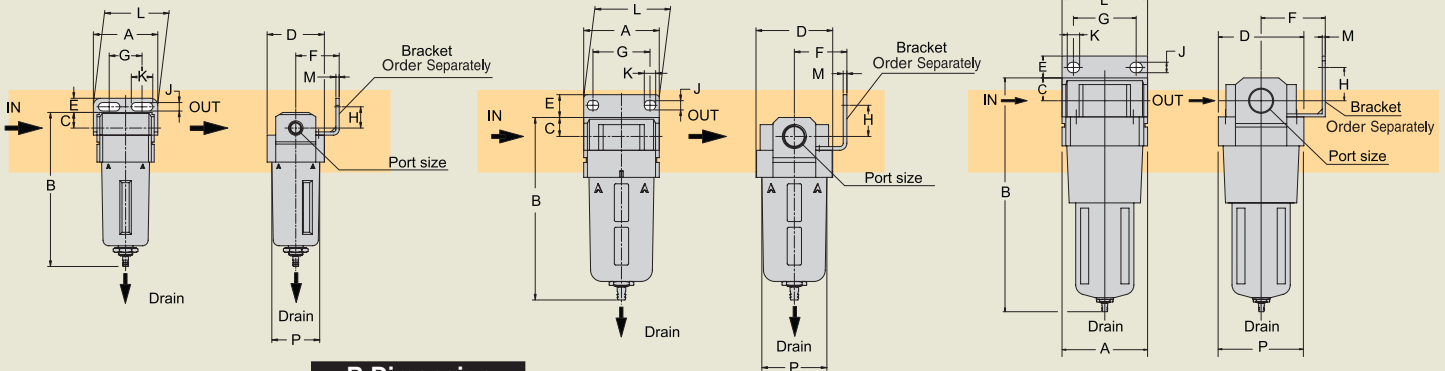

B Dimension

Body Size	Port Size	B Dimension			C	D	E	F	G	H	J	K	L	M	P
		A	Manual Drain	Auto Drain Float type											
FA2	1/8, 1/4	1.6(40)	4.3(110)	4.2(108)	0.4(11)	1.6(40)	0.7(17)	1.2(30)	1.0(26)	0.9(22)	0.21(5.4)	0.53(13.4)	1.8(45)	0.09(2.3)	1.3(34)
FA3	1/4, 3/8	2.1(53)	5.1(130)	5.4(138)	0.6(14)	2.1(53)	0.6(16)	1.6(41)	1.3(34)	0.9(23)	0.26(6.5)	0.49(12.5)	2.1(53)	0.09(2.3)	1.8(46)
FA4	1/2, 3/4	2.8(70)	7.2(184)	7.2(184)	0.7(18)	2.8(70)	0.7(17)	2.0(50)	1.7(42)	1.0(26)	0.33(8.5)	0.81(20.5)	2.8(70)	0.09(2.3)	2.4(62)
FA5	3/4, 1	3.5(90)	11.2(285.5)	11.2(284)	0.9(24)	3.5(90)	0.9(23)	2.8(70)	2.1(54)	1.4(35)	0.33(8.5)	0.47(12.0)	3.0(76)	0.09(2.3)	3.5(90)

Specifications

Series / Model Size	FA2	FA3	FA4	FA5
Port size	NPT 1/8, 1/4	1/4, 3/8	1/2, 3/4	3/4, 1
Operating media	Air			
Max. operating pressure: psi (MPa) (bar)	145 (1.0) (10)			
Max. flow rate* Filter	53(1500)	127(3600)	204(5800)	420(12000)
Mist Separator	7(200)	15(450)	38(1100)	NA
Temperature range	-5° to 52°C (23° to 125°F)			
Filtration	Standard 5μ	5μ	5μ	40μ
Bowl material	Polycarbonate			
Drain Capacity	Fl. oz(cc)	0.25(8)	0.6(20)	1.5(45)
Weight	lb.(Kg)	0.2(0.1)	0.5(0.2)	0.9(0.4)
				2.1(1.0)

* Flow SCFM (Lpm) @ 102 psi (0.7 MPa)(7bar) inlet pressure.

Accessories and Mounting See pages 22 & 23.

Accessories	FA2	FA3	FA4	FA5
Standard Interface	NS2	NS3	NS4	NS5
"T" Ported Interface	NT2-1P, NT2-2P	NT3-1P, NT3-2P	NT4-2P, NT4-3P	NA
Lock Out/Tag Out Valve	LT2-1P, LT2-2P	LT3-2P, LT3-3P	LT4-4P, LT4-5P	NA
Sleeve Valve	SV-2P	SV-2P; SV-3P	SV-4P	NA
Mounting				
MBFL Mounting Bracket	MBFL2	MBFL3	MBFL4	MBFL5

Replacement Parts See page 23.

Filter Element: 1μ, 5μ, 25μ & 40μ
Complete Bowl w/Auto Drain
Complete Bowl w/Manual Drain
Bowl Only for Filter / Mist Separator
Bowl Guard for Filter / Mist Separator

Filter Flow Characteristics - Inlet pressure = P₁ (See specification chart for mist separator maximum flow rate.)

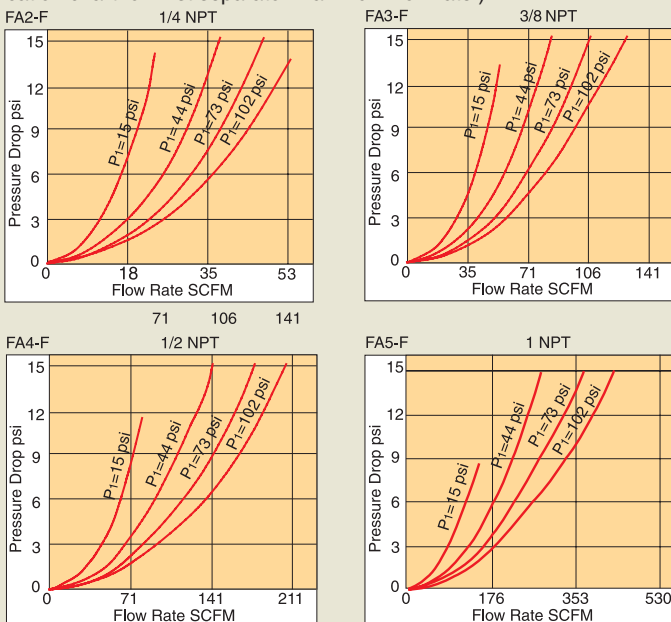

Air Supply

⚠ Caution

1. This product is specifically designed for compressed air service, and use with any other fluid (liquid or gas) is a misapplication. For example, use with or injection of certain hazardous liquids or gasses into the system (such as alcohol or liquid petroleum gas) could be harmful to the unit or result in a combustible condition or hazardous external leakage. Manufacturer's warranties are void in the event of misapplication and manufacturer assumes no responsibility for any resulting loss.
2. Install an air filter as a preliminary filter on the inlet side of the mist separator to prevent unwanted clogging.
3. Supply and outlet connections must be made to ports marked "IN", "OUT" or marked with directional symbols.
4. Some compressor oils, cleaners, chemicals, solvents, paints and fumes will attack plastic bowls and may cause plastic bowl failure. Inspect bowls frequently to detect crazing, cracking, damage or deterioration. Immediately replace any crazed, cracked, damaged or deteriorated bowls.
5. Do not install on a compressed air line where the compressor is lubricated with, or the air contains, a material that will attack plastic bowls.
6. Vibration during transit of new equipment may loosen the filter and/or lubricator bowls. Check to be certain the bowls and guards are completely locked into position before pressurizing the unit.

Installation

⚠ Caution

1. Install this unit ahead of equipment that requires filtered air.
2. Install unit in a vertical position with filter bowl at bottom.
3. The mist separator should be installed in a pulsation-free location. Differential pressure greater than 15 psi may cause damage to this item and other downstream components.
4. Do not use for pressures lower than rated. F.R.L. unit has its own minimum operating pressure determined by the equipment and is designed specifically to function with compressed air. If used below the minimum operating pressure, a loss of performance and breakdown may occur.
5. Do not allow air flow more than rated flow. If the air flow is permitted outside the range of rated flow, even momentarily, drainage and filtered contaminants may splash through the outlet and may cause damage to this item and other downstream components.

Maintenance

⚠ Warning

1. **DE-PRESSURIZE UNIT BEFORE ATTEMPTING TO REMOVE ANY COMPONENT, GUARD OR BOWL.**
2. Replace the filter element every 2 years or when the pressure differential approaches 15 psi, whichever comes first, to prevent damage to the element.
3. Replace all bowl guards and lock securely before pressurizing.



Regulator with "MBCR" Type Mounting Bracket

FABCO-AIR, Inc. • 3716 N.E. 49th Avenue • Gainesville, FL 32609 • Tel (352) 373-3578

Steel "MBCR" type mounting bracket and panel nut included



Regulators feature square embedded outlet pressure gauge with psi scale (145 psi = 1.0 MPa = 10 bar) and one "MBCR" Type mounting bracket and panel nut. Gauge for size 5 is round 1/4 NPT thread (bar and psi scale).

Orange stripe shows when knob is pulled away from housing allowing knob rotation to make outlet pressure adjustments.



SEE PRODUCT PRECAUTIONS ON PAGE 19.

How to Order

Series FA; Size 2, 3, 4 or 5 Description: Regulator

FA2 - R 2P

Port Size NPT:

1P=1/8; 2P=1/4;
3P=3/8; 4P=1/2;
5P=3/4; 6P=1

Pressure range for regulator - Option:

Blank for standard 5 to 125 psi
L = 5 to 35 psi
S = 5 to 60 psi

Gauge - Option:

Blank for standard
B = Block off plate
C = 1/8 NPT adapter plate
D = 1/4 NPT adapter plate
F = Small round gauge with 1/8 NPT adapter plate
G = Large round gauge with 1/4 NPT adapter plate
M = Square embedded MPa scale

Ordering Examples

Port NPT	Model No.
1/8	FA2-R1P
1/4	FA2-R2P
1/4	FA3-R2P
3/8	FA3-R3P
1/2	FA4-R4P
3/4	FA4-R5P
3/4	FA5-R5P
1	FA5-R6P

External Dimensions – inch (mm)

Size FA2 –

1.32(33.5 mm) Dia.
Panel Hole Required

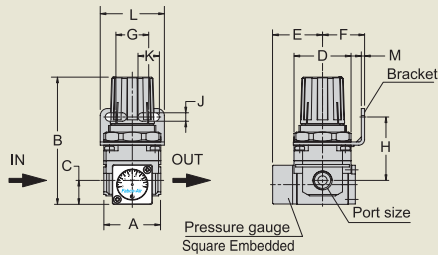
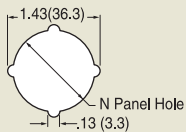

Size FA5 –

2.06(52.3 mm) Dia.
Panel Hole Required

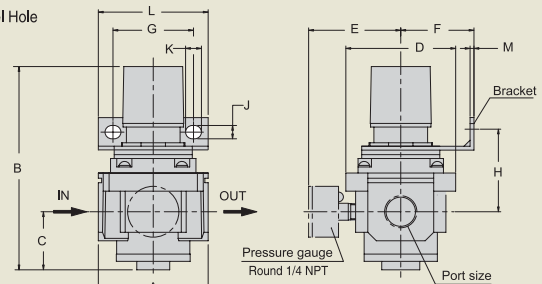
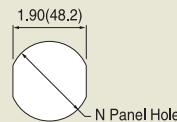

Sizes FA3 & 4 –

1.68(42.5 mm) Dia.
Panel Hole Required

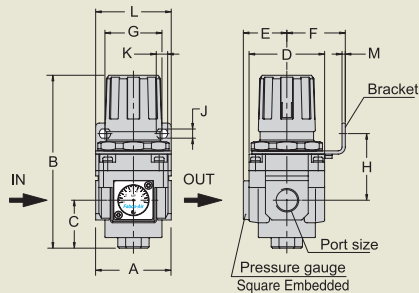
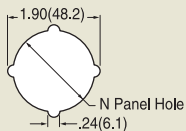

Body Size	Port Size	A	B	C	D	E	F	G	H	J	K	L	M	Panel Hole N
FA2	1/8, 1/4	1.6(40)	3.7(93)	0.6(14)	1.6(40)	1.3(34)	1.2(30)	1.02(26)	1.9(48)	.21(5.4)	.53(13.4)	1.8(45)	.09(2.3)	1.32(33.5)
FA3	1/4, 3/8	2.1(53)	4.7(120)	1.3(34)	2.1(53)	1.2(30)	1.6(41)	1.34(34)	1.8(46)	.26(6.5)	.49(12.5)	2.2(55)	.09(2.3)	1.68(42.5)
FA4	1/2, 3/4	2.8(70)	5.0(127)	1.6(40)	2.3(57.5)	1.5(38)	2.0(50)	1.65(42)	2.1(54)	.33(8.5)	.81(20.5)	2.8(70)	.09(2.3)	1.68(42.5)
FA5	3/4, 1	3.5(90)	6.7(169)	1.7(43)	3.4(87)	3.3(84)	2.0(51)	1.75(44.5)	2.6(65.8)	.26(6.5)	.61(15.5)	2.6(67)	.13(3.2)	2.06(52.3)

Specifications - Precautions

FABCO-AIR Inc. • Fax (352) 375-8024 • E-Mail: fabco@fabco-air.com • Web Site: www.fabco-air.com

Installation

⚠ Caution

1. This product is specifically designed for compressed air service, and use with any other fluid (liquid or gas) is a misapplication. For example, use with or injection of certain hazardous liquids or gasses into the system (such as alcohol or liquid petroleum gas) could be harmful to the unit or result in a combustible condition or hazardous external leakage. Manufacturer's warranties are void in the event of misapplication and manufacturer assumes no responsibility for any resulting loss.
2. Contaminants in the compressed air stream must be filtered and drained with a suitable component before reaching this regulator product.
3. Install the component that is the same pipe size as the line on which it is to be mounted. Do not use fittings that may restrict air flow.
4. Supply and outlet connections must be made to ports marked "IN", "OUT" or marked with directional symbols.
5. Unit must be mounted with adjusting knob in vertical attitude either up or down.
6. Install this unit ahead of equipment that requires regulated pressure.
7. When using in combination with a lubricator, always install this regulator before the lubricator.

Specifications

Series / Model Size	FA2	FA3	FA4	FA5
Port size NPT	1/8, 1/4	1/4, 3/8	1/2, 3/4	3/4, 1
Operating media	Air			
Max. operating pressure: psi (MPa) (bar)	145 (1.0) (10)			
Regulating range: psi (MPa) (bar)	Standard 5 to 125 (0.04 to 0.85) (0.4 to 8.5)			
Max. flow rate*	28(800)	53(1500)	106(3000)	350(10000)
Temperature range	-5° to 52°C (+23° to 125°F)			
Construction	Relieving type			
Weight lb.(Kg)	0.4(0.2)	0.7(0.33)	1.9(0.85)	2.7(1.2)

* Flow SCFM (Lpm) @ 102 psi (0.7 MPa)(7bar) inlet pressure.

Flow Characteristics - Inlet pressure = 102 psi

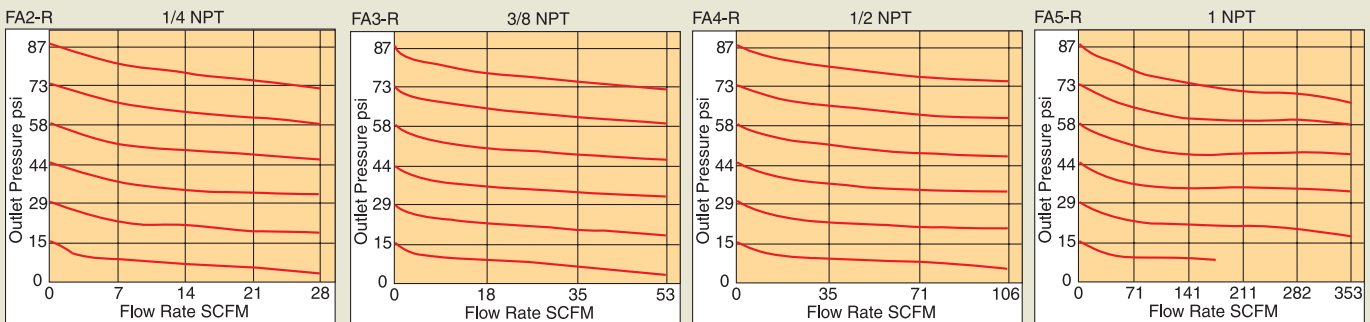

Pressure Characteristics

Set point conditions: Inlet pressure = 102 psi; Outlet pressure = 29 psi; Flow rate = 0.7 SCFM

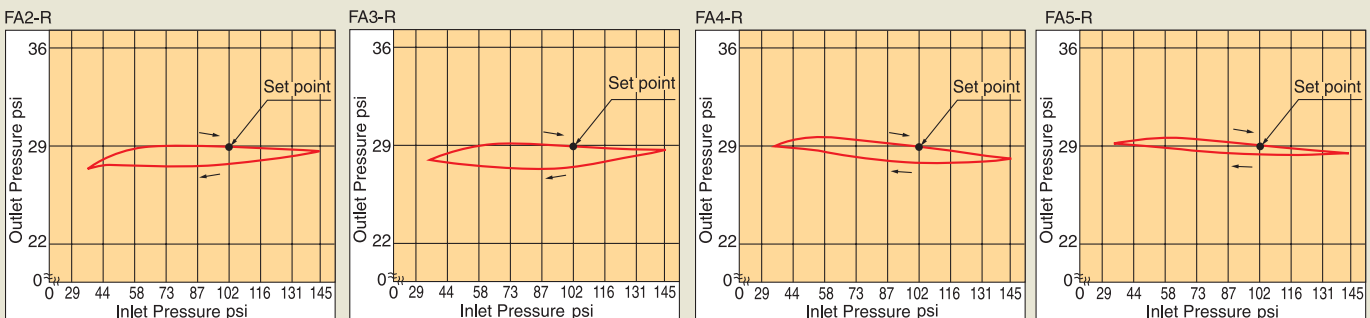

Adjustment

⚠ Warning

1. Adjust the regulator while monitoring inlet and outlet pressure gauges. Turning the knob beyond reasonable resistance may damage internal parts.
2. The regulator is intended to be adjusted manually. Do not use tools on the regulator knob as this can cause damage.

⚠ Caution

- Pull the regulator knob to unlock. (Orange stripe will appear in the gap.)
- Make sure the knob is unlocked before adjusting the pressure and lock it after setting the pressure. Failure to unlock or lock may damage the knob or other parts and the outlet pressure may vary from expected settings.
- Push the regulator pressure knob to lock. If the knob is not easily locked, adjust it left or right slightly and then push to lock. (The orange stripe will be covered when the knob is locked.)

Replacement Parts

See page 23.

Regulator diaphragm
Regulator knob
Spring: 5 to 125 psi
Spring: 5 to 35 psi
Spring: 5 to 60 psi

Mounting

See page 22.

Size	Mounting Bracket
FA2	MBCR2
FA3	MBCR3
FA4	MBCR4
FA5	MBCR5

Accessories

– See pages 22 & 23 for Interfaces, 3-Way Sleeve Valves, Lock Out/Tag Out Valves, Gauges and block off plates.



Order Mounting Brackets and Interface Blocks separately. See pages 22 and 23.



SEE PRODUCT PRECAUTIONS ON PAGE 21.

How to Order

Series FA; Size 2, 3, 4 or 5
Description: Lubricator

FA3 - L 3P

Port Size NPT:
1P=1/8 2P=1/4 3P=3/8 4P=1/2 5P=3/4 6P=1

Ordering Examples

Port Size	Model No.
1/8	FA2-L1P
1/4	FA2-L2P
1/4	FA3-L2P
3/8	FA3-L3P
1/2	FA4-L4P
3/4	FA4-L5P
3/4	FA5-L5P
1	FA5-L6P

External Dimensions - inch (mm)

Size FA2

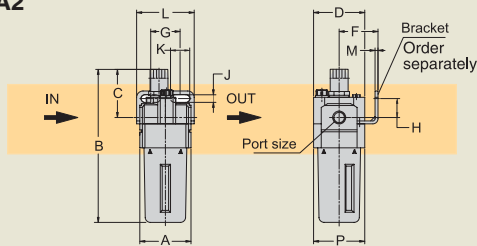

Sizes FA5

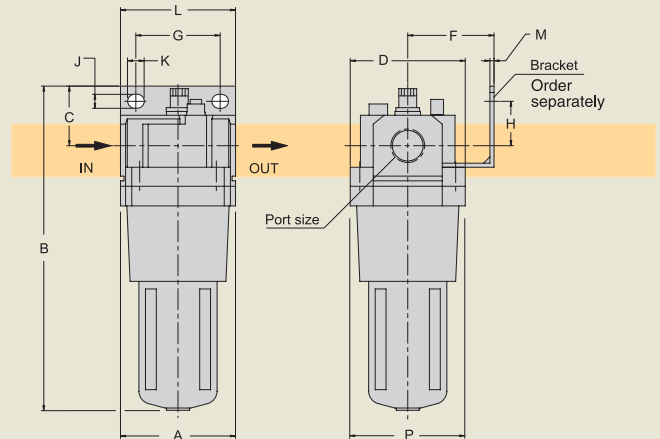

Sizes FA3 & 4

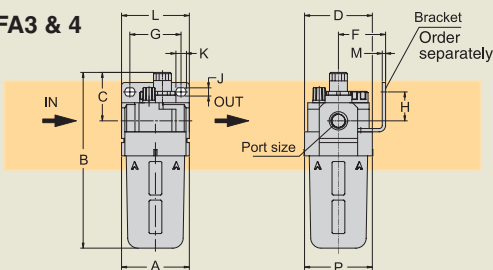

Body Size	Port Size	A	B	C	D	F	G	H	J	K	L	M	P
FA2	1/8, 1/4	1.6(40)	4.9(125)	1.6(40)	1.6(40)	1.2(30)	1.0(26)	0.9(22)	0.21(5.4)	0.53(13.4)	1.8(45)	0.09(2.3)	1.3(34)
FA3	1/4, 3/8	2.1(53)	5.9(150)	1.7(44)	2.1(53)	1.6(41)	1.3(34)	0.9(23)	0.26(6.5)	0.49(12.5)	2.1(53)	0.09(2.3)	1.8(46)
FA4	1/2, 3/4	2.8(70)	7.9(200)	1.9(48)	2.8(70)	2.0(50)	1.7(42)	1.0(26)	0.33(8.5)	0.81(20.5)	2.8(70)	0.09(2.3)	2.4(62)
FA5	3/4, 1	3.5(90)	9.8(250)	1.6(41)	3.5(90)	2.8(70)	2.1(54)	1.4(35)	0.33(8.5)	0.47(12.0)	3.0(76)	0.09(2.3)	3.5(90)

Specifications - Precautions

FABCO-AIR Inc. • Fax (352) 375-8024 • E-Mail: fabco@fabco-air.com • Web Site: www.fabco-air.com

Specifications

		1/8, 1/4	1/4, 3/8	1/2, 3/4	3/4, 1
Port size	NPT	1/8, 1/4	1/4, 3/8	1/2, 3/4	3/4, 1
Operating media					
Max. operating pressure: psi (MPa) (bar)					
Min. dripping flow rate: SCFM(LPM)		0.5(15)	1/4:1.0(30) 3/8:1.4(40)	1.7(50)	6.7(190)
Temperature range		-5° to 52°C (+23° to 125°F)			
Recommended oil		Turbine oil (ISO VG32) Exxon Terrestrial GT32, Castrol Hyspin R&O 32, or equal			
Bowl Capacity	- Max. Fl. oz(cc)	0.5(14)	1.5(44)	2.5(73)	4.2(125)
	-Min Fl oz(cc)	0.12(4)	0.5(14)	0.5(14)	1(29)
Bowl material					
Weight	lb.(Kg)	0.4(0.18)	0.5 (0.22)	1.1(0.5)	2.4(1.1)

Replacement Parts

See page 23.

Lubricator bowl
Bowl guard
Lubricator pick up tube
Lubricator adjuster
Lubricator Plug for fill port

Accessories & Mounting

See pages 22 and 23.

Accessories	FA2	FA3	FA4	FA5
Standard Interface	NS2	NS3	NS4	NS5
"T" Ported Interface	NT2-1P, NT2-2P	NT3-1P, NT3-2P	NT4-2P, NT4-3P	NA
Lock Out/Tag Out Valve	LT2-1P, LT2-2P	LT3-2P, LT3-3P	LT4-4P, LT4-5P	NA
Sleeve Valve	SV-2P	SV-2P; SV-3P	SV-4P	NA
Mounting				
MBFL Mounting Bracket	MBFL2	MBFL3	MBFL4	MBFL5

Flow Characteristics - Inlet pressure = P₁

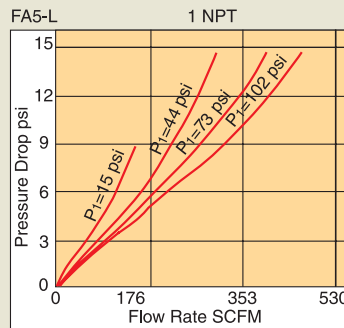
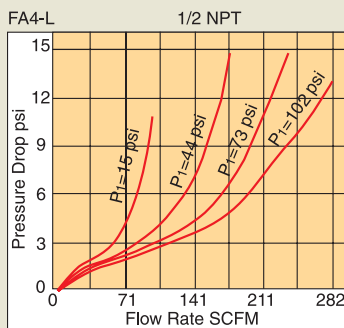
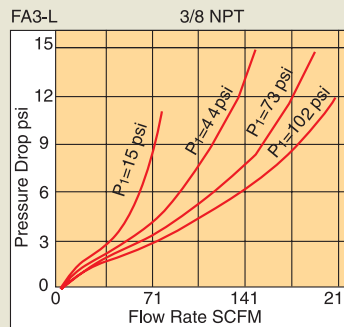
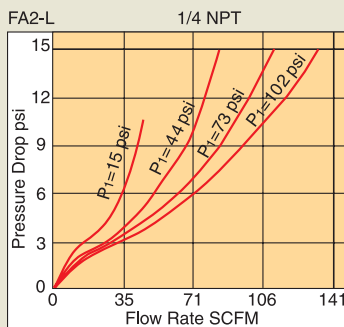

Product Precautions

Installation

Warning

1. This product is specifically designed for compressed air service, and use with any other fluid (liquid or gas) is a misapplication. For example, use with or injection of certain hazardous liquids or gasses into the system (such as alcohol or liquid petroleum gas could be harmful to the unit or result in a combustible condition or hazardous external leakage. Manufacturer's warranties are void in the event of misapplication and manufacturer assumes no responsibility for any resulting loss.
2. Contaminants in the compressed air stream must be filtered and drained with a suitable component before reaching this lubricator product.
3. Install as close as possible to the equipment which is to be lubricated. Be sure lubricator is accessible for easy filling.
4. Supply and outlet connections must be made to ports marked "IN", "OUT" or marked with directional symbols.
5. Install the same size unit as the pipe in use. Avoid using fittings, couplings, etc., that restrict airflow.
6. Vibration during transit of new equipment may loosen the filter and/or lubricator bowls. Check to be certain the bowls and guards are completely locked into position before pressurizing the unit.
7. Fill lubricator prior to pressurization by pouring oil into the bowl through the fill port.
8. Pressure must be disconnected from the lubricator and downstream air must be vented before removing the fill plug. Replenish the supply of lubricator oil through the fill port to the indicated level.
9. **USE CLEAN, NON-DETERGENT OIL**, preferably SAE 10 or lighter, such as Exxon Terrestrial GT32 or equal. The rate of oil delivery may be controlled by turning the adjusting screw counter clockwise for more and clockwise for less oil. Once set, the variable orifice in the lubricator will maintain the same ratio of oil to air flow regardless of any change in the airflow rate.

Maintenance

Warning

1. **BEFORE SERVICING THIS UNIT READ ALL PRODUCT PRECAUTIONS ON PAGES 17, 19 AND 21.** Note the special warning information that applies to plastic bowls
2. **DE-PRESSURIZE UNIT BEFORE ATTEMPTING TO REMOVE ANY COMPONENT, GUARD OR BOWL.**
3. Inspect plastic bowls daily to detect crazing, cracking, damage or other deterioration. Immediately replace any crazed, cracked, damaged or deteriorated bowls.
4. Periodically remove the adjusting screw and clean the needle and the seat in the body by blowing off with an air blow gun.
5. If siphon tube is equipped with a filter, occasionally clean the filter by blowing off with an air blow gun.
6. Drain off any contaminants which collect in the bottom of the bowl.
7. Replace all bowl guards before pressurizing.

Standard Interface

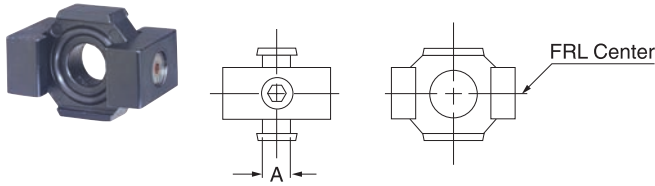

Size	Part No.	A
2	NS2	0.39(10)
3	NS3	0.43(11)
4	NS4	0.55(14)
5	NS5	0.59(15)

“T” Interface

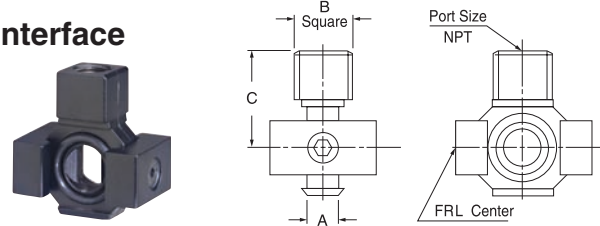

Size	Port NPT	Part No.	A	B	C
2	1/8	NT2-1P	0.39(10)	0.75(19)	1.14(29)
2	1/4	NT2-2P	0.39(10)	0.75(19)	1.14(29)
3	1/8	NT3-1P	0.43(11)	0.75(19)	1.30(33)
3	1/4	NT3-2P	0.43(11)	0.75(19)	1.30(33)
4	1/4	NT4-2P	0.55(14)	0.94(24)	1.54(39)
4	3/8	NT4-3P	0.55(14)	0.94(24)	1.54(39)

Mounting Bracket “MBL” Type

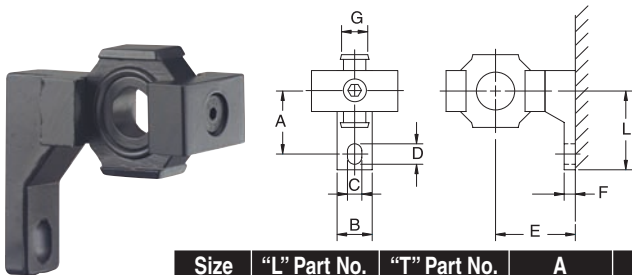

Size	“L” Part No.	“T” Part No.	A	B	C	D	E	F	G	L
2	MBL2	MBT2	0.94(24)	.59(15)	.22(5.5)	.33(8.5)	1.18(30)	.20(5)	.39(10)	1.30(33)
3	MBL3	MBT3	1.38(35)	.63(16)	.28(7)	.43(11)	1.61(41)	.28(7)	.43(11)	1.77(45)
4	MBL4	MBT4	1.57(40)	.87(22)	.35(9)	.59(13)	1.97(50)	.28(7)	.55(14)	1.97(50)
5	MBL5	MBT5	1.97(50)	.94(24)	.47(12)	.63(16)	2.76(70)	.39(10)	.59(15)	2.46(62.5)

Mounting Bracket “MBT” Type

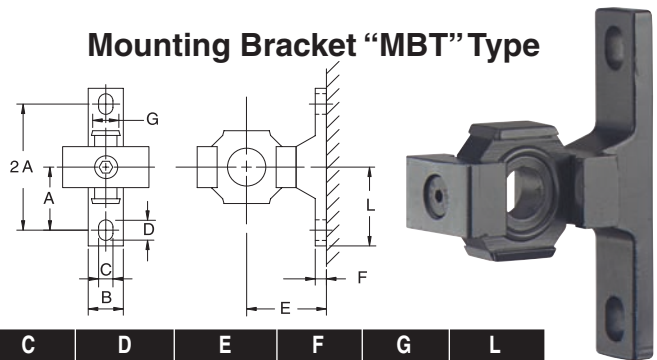

Mounting Bracket for Filters & Lubricators
 Screws included

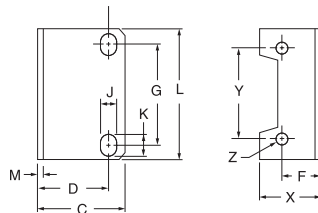

Size	Part No.	C	D	F	G	J	K	L	M	X	Y	Z
2	MBFL2	1.32(33.5)	1.06(27)	0.55(14)	1.02(26)	0.21(5.4)	0.53(13.4)	1.77(45)	.09(2.3)	0.74(18.8)	1.02(26)	.18(4.5)
3	MBFL3	1.54(39)	1.26(32)	0.75(19)	1.34(34)	0.26(6.5)	0.49(12.5)	2.09(53)	.09(2.3)	0.89(22.5)	1.38(35)	.18(4.5)
4	MBFL4	1.85(47)	1.50(38)	0.79(20)	1.65(42)	0.33(8.5)	0.81(20.5)	2.76(70)	.09(2.3)	1.14(29)	1.85(47)	.22(5.5)
5	MBFL5	2.16(55)	1.77(45)	0.67(17)	2.13(54)	0.33(8.5)	0.47(12)	3.00(76)	.09(2.3)	0.99(25.2)	2.36(60)	.26(6.5)

Mounting Bracket for Filter/Regulators & Regulators

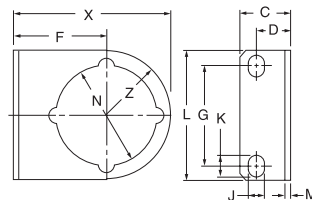

Size	Part No.	C	D	F	G	J	K	L	M	N	X	Z
2	MBCR2	1.00(25.5)	.75(19)	1.18(30)	1.02(26)	.21(5.4)	.53(13.4)	1.77(45)	.09(2.3)	1.30(33)	2.05(52)	.87(22)
3	MBCR3	0.89(22.5)	.59(15)	1.61(41)	1.34(34)	.26(6.5)	.49(12.5)	2.17(55)	.09(2.3)	1.65(42)	2.70(68.5)	1.08(27.5)
4	MBCR4	1.08(27.5)	.73(18.5)	1.97(50)	1.65(42)	.33(8.5)	.81(20.5)	2.76(70)	.09(2.3)	1.65(42)	3.15(80)	1.18(30)
5	MBCR5	0.98(25)	.71(18)	2.00(51)	1.75(44.5)	.26(6.5)	.61(15.5)	2.64(67)	.09(2.3)	2.05(52)	3.33(84.5)	1.32(33.5)

Accessories / Replacement Parts – Dimension units are inch(mm)

FABCO-AIR Inc. • Fax (352) 375-8024 • E-Mail: fabco@fabco-air.com • Web Site: www.fabco-air.com

Pressure Gauge (Square Embedded)

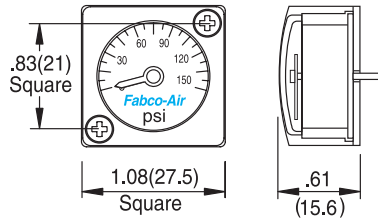

Scale	Part No.
psi	GS-P
MPa	GS-M

Round Pressure Gauge

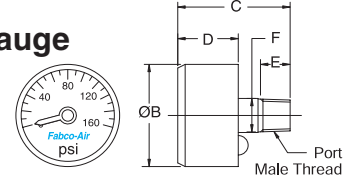

(Requires adapter plate) Center back male thread with dual scale bar & psi

Dimensions						
Port	Part No.	ØB	C	D	E	F Square
1/8	GR-1P	1.46(37)	1.61(40.8)	.94(23.8)	.39(10)	.47(12)
1/4	GR-2P	1.65(42)	1.75(44.5)	.96(24.5)	.47(12)	.55(14)

Gauge Adapter Plate (Required for round gauge)



NPT	Part No.
1/8	GA-1P
1/4	GA-2P

Gauge Port Block Off (When no gauge needed)



Part No.
GA-XP

Regulator Mounting Nuts

Size	Part No.
2	FA2-N
3 & 4	FA3-N
5	FA5-N

3-Way Lock-out / Tag-out Valve

Connect to FRL components with NPT port or interface items.

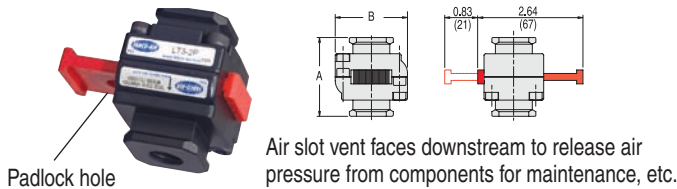

Size	Port NPT	Model No.	A	B
2	1/8	LT2-1P	1.65(42)	1.89(48)
2	1/4	LT2-2P	1.65(42)	1.89(48)
3	1/4	LT3-2P	2.00(51)	1.81(46)
3	3/8	LT3-3P	2.00(51)	1.81(46)
4	1/2	LT4-4P	2.36(60)	2.28(58)
4	3/4	LT4-5P	2.36(60)	2.28(58)

3-Way Slide Valve

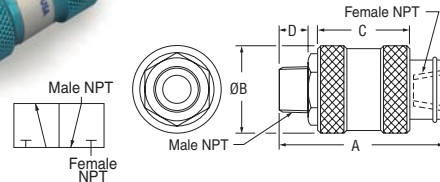
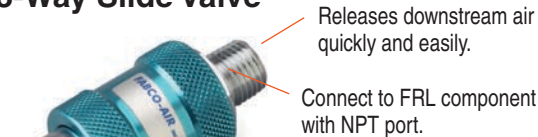

Model No.	NPT	SCFM	A	B	C	D
SV-2P	1/4	35	2.28(58)	1.02(26)	1.26(32)	.41(10.3)
SV-3P	3/8	49	2.26(57.5)	1.22(31)	1.26(32)	.39(10)
SV-4P	1/2	70	3.61(91.6)	1.50(38)	1.93(49)	.53(13.5)

Replacement Parts

Description	Size FA2	Size FA3	Size FA4	Size FA5
	Part No.	Part No.	Part No.	Part No.
Filter Element 1µ	FA2-M1	FA3-M1	FA4-M1	Not Available
5µ	FA2-F5	FA3-F5	FA4-F5	FA5-F5
25µ	FA2-F25	FA3-F25	FA4-F25	FA5-F25
40µ	FA2-F40	FA3-F40	FA4-F40	FA5-F40
Complete Bowl w/Auto Drain	FA2-F905A	FA3-F905A	FA4-F905A	FA5-F905A
Complete Bowl w/Manual Drain	FA2-F905M	FA3-F905M	FA4-F905M	FA5-F905M
Bowl only for Filter	FA2-F905	FA3-F905	FA4-F905	FA5-F905
Bowl Guard	FA2-F904	FA3-F904	FA4-F904	FA5-F904
Regulator Diaphragm	FA2-R911	FA3-R911	FA4-R911	FA5-R911
Regulator Knob	FA2-R902	FA3-R902	FA4-R902	FA5-R902
Lubricator bowl	FA2-L905	FA3-L905	FA4-L905	FA5-L905
Lubricator pick up tube	FA2-L911	FA3-L911	FA4-L911	FA5-L911
Lubricator adjuster	FA2-L908	FA2-L908	FA2-L908	FA5-L908
Lubricator Plug for fill port	FA2-L906	FA3-L906	FA4-L906	FA4-L906

Fabco-Air Product Catalog Library



Cylinders, Valves & Accessories
Catalog CV9 details Pancake®, Square 1®, Multi-power®, Hi-Power™ and Longstroke™ air cylinder lines. Describes valves, air-over-oil tanks, boosters & accessories.

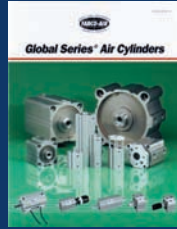

Global Series™ Air Cylinders
Cat. GC-15
 Widest choice of models and options. Features non-lube service to 150 psi. Bores 12mm to 100mm
 • Strokes 5mm - 150mm
 • NPT or Metric ports



Dual Function Slides
Bulletin EDF-10
 Either of two slide styles (gantry or thruster) can be made from a single set of parts. Users can inventory less parts and assemble styles as needed.

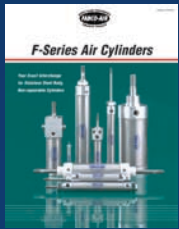

Stainless Steel Body Air Cylinders
Catalog SSB-03
 Exact interchange in bores from 5/16" to 3", strokes to 32". Popular options includes magnetic piston, non-rotating, and position feedback.



Multi-Power® Air Presses
Catalog FP16
 Details the powerful line of precision, force-multiplying air presses. Deliver forces to 11,000 pounds.



Swing Clamps
Bulletin #SC-DB04
 Clamp arm rotates 90° as it extends away from the workpiece. Features standard magnetic piston.



Pancake® II Cylinders
Catalog Pan2-2
 The direct industrial interchange. High strength composite cylinder barrel. 4 popular styles: Standard, Nonrotating, Multi-Power® and 3-position.



New Linear Thrusters
Bulletin GB-JA02
 Features longer strokes to 10" – and 4mm round profile sensors with surge suppression and polarity protection.

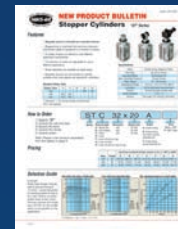

Stopper Cylinders
Bulletin #ST-DIX04
 Standard magnetic piston and a wide selection of styles. Roller direction is adjustable. Magnetic sensors can be mounted on body.

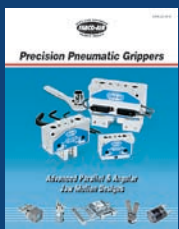

Pneumatic Grippers
Catalog GR-8
 • SPG & LPG parallel jaw motion with strokes from 1/4" to 24" & forces to 402 lbs. • GR & GS angular jaw styles with on-the-fly adjustment.



NFPA Interchangeable Air Cylinders
Catalog NF-6
 All the desirable NFPA mounts. Bores from 1-1/2" to 6"; strokes to 99". Aluminum or high strength composite cylinder body. Magnetic position sensing.



Specialty Valves and Control Valves
Bulletin #14CAN
 • Composite body solenoid valves in 2 or 3-way, N/O or N/C, and manifoldable configurations. • Process Solenoid valves. • 5 Ported, 3 position, 1/4 NPT 4-way air valves.

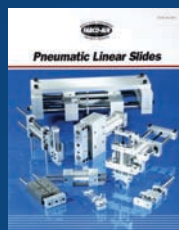

Linear Slides
Catalog # LS-03
 Line includes 6 families of slides, pick & place units, and thin parts placers. 5/16" to 4" bores. Guide shafts 1/4" to 1-1/2".



Square Pancake® II
Catalog SqPan2
 Drop-in interchangeable standard & non-rotating models. 3/4" to 4" bores. Strokes to 4". High strength composite barrel, hard chrome plated piston rod and more.

Distributed by: